



We put space to work.

Item # \_\_\_\_\_

Job \_\_\_\_\_

# Metro® Mightylite™ Insulated Front-Load Pan Carriers

Attractive, ultra light, and durable insulated front load pan carriers for transporting and delivering hot and cold 12x20/GN food pans to off-site locations.

- **Durable:** advanced polymer foam construction with high strength-to-weight ratio withstands impact without damage, making it perfect for lifting and withstanding the rigors of off-site food transport!
- **Ultra-light:** Mightylite front load pan carriers weigh 60% less than traditional polymer molded, urethane foam-filled carriers. ML300 weighs 9.1 lbs. (4.1kg) and ML400 is 11.3 lbs. (5.1kg)
- **Ergonomic:** convenient, integrated handles provide the ultimate flexibility to facilitate lifting, carrying, and moving in various situations. Eight handles make the job easier and allow you to lift whichever way makes you most comfortable!
- **Keeps Food Safe for 5+ Hours!** Transport hot or cold food at safe, appetizing temperatures with confidence.
- **Robust Door Design:** 270° swing door with flexible integrated seal, snaps shut and helps retain temperature. Never worry about replacing or difficult to clean gaskets again. Integrated hinges and durable elastomer travel latch are virtually unbreakable!
- **Label Holder/Whiteboard:** doubles as card holder and dry erase board, and makes identifying carrier contents and destination easier.
- **Stackable:** carriers are designed to interlock with each other and optional dolly for more efficient transportation and storage.
- **Complimentary Wire Caddy:** included with every carrier to help organize and hold common temperature maintenance tools and other odd shaped items such as quart containers.
- **Recyclable:** 100% recyclable, CFC free.

Patents Pending



ML300 & ML400  
stacked on optional dolly

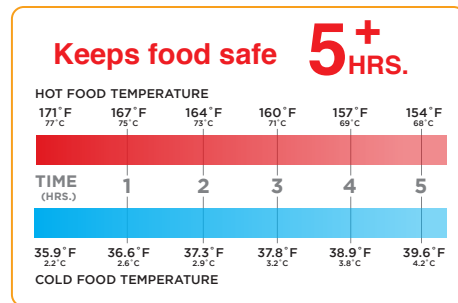

ML300

ML400

All Metro Catalog Sheets are available on our website: [www.metro.com](http://www.metro.com)



**InterMetro Industries Corporation**  
North Washington Street, Wilkes-Barre, PA 18705  
Product Information. U.S. and Canada: 1.800.992.1776  
Outside U.S. and Canada: [www.metro.com/contactus](http://www.metro.com/contactus)

L03-293  
Printed in U.S.A. Rev. 8/18

Information and specifications are subject to change without notice. Please confirm at time of order.

Copyright © 2018 InterMetro Industries Corp.



**Metro® Mightylite™ Insulated Front-Load Pan Carriers**

**13-60**

Job \_\_\_\_\_



# Metro® Mightylite™ Insulated Front-Load Pan Carriers

We put space to work.®

## Specifications

- **Carrier Construction:** Lightweight, thermally insulated, impact absorbing, eco-friendly engineered plastic foam body and door made of expanded polypropylene (EPP). 2" (51mm) thick walls.
- **Door:** 270° swing flush, vaulted door with flexible integrated door seal and large 5.5" (140mm) x 8.5" (216mm) clear polyester label holder/whiteboard.
- **Hinge:** Integral to carrier body, with heavy-duty 5/16" (8mm) diameter stainless steel pin.
- **Travel Latch:** Heavy-duty elastomer travel latch, secured to body with 5/16" (8mm) diameter stainless steel pin. Removable without the use of tools.
- **Pan Slides:** Integral to carrier walls, spaced on 1 1/2" centers.

CARRIERS ARE 17.25" (438mm) WIDE AND 27" (686mm) DEEP

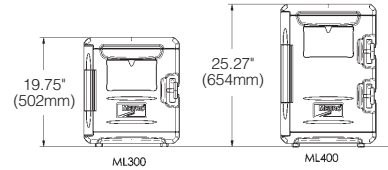

CARRIERS STACKED ON DOLLY ARE 20.63" (524mm) WIDE AND 29.75" (756mm) DEEP

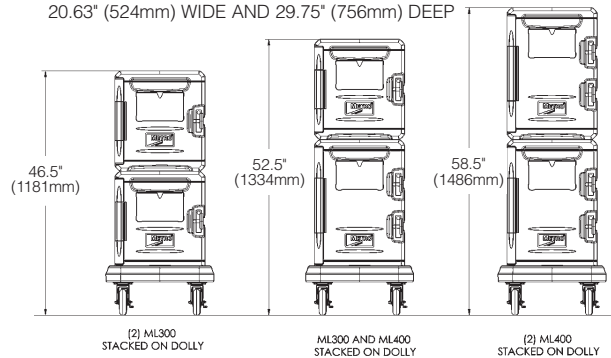

## Accessories

- **Dolly:** heavy-duty high density polyethylene (HDPE) construction fastened to 0.100" (2.5mm) thick aluminum caster channels with rugged 5/16" (8mm) stainless steel tie down anchors. Plate mounted casters, 2 swivel and 2 wheel with brakes. 5" (127mm) diameter donut neoprene wheels. Load capacity 350 lbs. (158kg) per dolly. Includes 1" (25mm) x 15' (457 cm) long cam buckle strap with hooks. Dolly is designed to transport carriers but can be used for milk crates as well.
- **Wire Caddy:** can be used to hold hot and cold packs to extend holding times, as a support for disposable aluminum pans, or to organize and transport common items such as quart containers. Epoxy coated. One included with every carrier.
- **Carrying strap:** Heavy-duty adjustable strap, designed to work with top-load and front-load carriers. Detachable handles can be quickly re-configured for one-handed or two-person carrying. 1" (25mm) wide, high-strength polyester webbing with low water absorption properties. Box sewn stitch pattern with durable polymer / metal hardware.
- **Thermal Partition:** 1.5" (38mm) thick insulated partition helps avoid accelerated food temperature loss or gain inside partially full carriers by minimizing empty space inside the carrier. Also use to separate hot and cold food in one carrier.



MLD1 Dolly (includes strap)



MLP1 Thermal Partition & MLC1 Wire Caddy inside ML300



Dolly designed to hold milk crates



MLS1 Carrying Strap

## Dimensions, Weights, & Food Capacity

Model	Description	Product Dimensions (W x D x H)	Weight	12" x 20" — GN 1/1 Pan Capacity			Food Capacity (approx.)	Shipping	
				2.5" / 65mm	4" / 100mm	6" / 150mm		Weight	Volume
ML300	ML300 Carrier	17.25"x27"x19.75" (438x686x502mm)	9.1 lbs. (4.1kg)	4	3	2	45 qts. (42.5 L)	11.6 lbs. (5.3kg)	5.7 ft. <sup>3</sup> (0.16 m <sup>3</sup> )
ML400	ML400 Carrier	17.25"x27"x25.75" (438x686x654mm)	11.3 lbs. (5.1kg)	6	4	3	60 qts. (56.8 L)	14.1 lbs. (6.4kg)	7.3 ft. <sup>3</sup> (0.21 m <sup>3</sup> )
MLD1	Dolly	20.63"x29.75"x9.5" (524x756x241mm)	19.0 lbs. (8.6kg)	N/A	N/A	N/A	N/A	20.0 lbs. (9.1kg)	3.5 ft. <sup>3</sup> (0.99 m <sup>3</sup> )
MLP1	Thermal Partition	13"x21"x1.5" (330x533x38mm)	0.8 lbs. (0.4kg)	N/A	N/A	N/A	N/A	1.5 lbs. (0.7kg)	0.3 ft. <sup>3</sup> (0.01 m <sup>3</sup> )
MLC1	Wire Caddy	13"x21"x1" (330x533x25mm)	1.3 lbs. (0.6kg)	N/A	N/A	N/A	N/A	2.0 lbs. (0.9kg)	0.3 ft. <sup>3</sup> (0.01 m <sup>3</sup> )
MLS1	Carry Strap	N/A	N/A	N/A	N/A	N/A	N/A	0.5 lbs. (0.2kg)	0.2 ft. <sup>3</sup> (0.006 m <sup>3</sup> )

ML300 & ML400 will also hold 1/2, 1/3, 2/3 fractional sized hotel/GN pans.

an Ali Group Company



The Spirit of Excellence